

Technical information

Notes on equipment protection per EN/IEC 60529 and NEMA For Bourdon tube or diaphragm pressure gauges

WIKA data sheet IN 00.18

General information

This technical information describes the measures to prevent both the formation of condensation within a hermetically sealed case, and also the intrusion of water into cases vented to the atmosphere. It applies for both Bourdon tube pressure gauges and diaphragm pressure gauges.

1. Introduction and explanation of physical conditions

The formation of condensation in the cases of hermetically sealed, unfilled instruments cannot generally be avoided. This is based on the physical fact that the humidity found in air, under particular conditions, settles on cold surfaces as condensation. The warmer the air, the more humidity it can hold. If the air cools (e.g. at the window of a gauge), then the air can only hold a small amount of humidity. The excess humidity settles as condensation on the window.

In addition, water in the form of splash, jet and rain water from outside can intrude into the case, so long as the instrument is vented to atmosphere.

2. Explanation of the degrees of protection per EN/IEC 60529

Degrees of protection against solid foreign bodies, defined by the first index number

First index number	Degree of protection	
	Code designation	Definition
0	Not protected	–
1	Protected against solid foreign bodies of 50 mm diameter and larger	The object probe, a round body of 50 mm diameter, must not fully intrude ¹⁾
2	Protected against solid foreign bodies of 12.5 mm diameter and larger	The object probe, a round body of 12.5 mm diameter, must not fully intrude ¹⁾
3	Protected against solid foreign bodies of 2.5 mm diameter and larger	The object probe, 2.5 mm in diameter, must not intrude at all ¹⁾
4	Protected against solid foreign bodies of 1.0 mm diameter and larger	The object probe, 1.0 mm in diameter, must not intrude at all ¹⁾
5	Dust protected	Ingress of dust is not completely prevented, but dust may not intrude in a such a quantity that the satisfactory operation of the instrument or safety is impaired
6	Dust tight	No ingress of dust

1) The full diameter of the object probe must not pass through any opening in the case.

Illustration 1

Source: EN/IEC 60529

Degrees of protection against water, defined by the second index number

Second index number	Degree of protection	
	Code designation	Definition
0	Not protected	–
1	Protected against dripping water	Perpendicularly falling drops must have no damaging effects
2	Protected against dripping water when the case is inclined to 15°	Perpendicularly falling drops must have no damaging effects, when the case is inclined to an angle of up to 15°, either side of perpendicular
3	Protected against sprayed water	Water that is sprayed at an angle of up to 60°, either side of perpendicular, must have no damaging effects
4	Protected against splash water	Water that splashes against the case from any direction must have no damaging effects
5	Protected against water jets	Water that splashes against the case, as a jet, from any direction, must have no damaging effects
6	Protected against strong water jets	Water that splashes against the case, as a strong jet, from any direction, must have no damaging effects
7	Protected against the effects of temporary immersion in water	Water must not enter in any quantity which could cause damage, when the case, under standardised pressure and temperature conditions, is temporarily immersed in water
8	Protected against the effects of permanent immersion in water	Water must not enter in any quantity which could cause damage, when the case is permanently immersed in water, under conditions which must be agreed between the manufacturer and user. The conditions must, however, be more demanding than those for the index number 7

Illustration 2

Source: EN/IEC 60529

Example: Ingress protection IP65

- First index number 6: Dust tight, no ingress of dust
- Second index number 5: Protected against water jets: Water that splashes against the case as a jet from any direction must have no damaging effects.

3. Comparison of NEMA (National Electrical Manufacturers Association) and EN/IEC 60529

NEMA ingress protection Model number	EN/IEC 60529 ingress protection Classification
1	IP10
2	IP11
3	IP54
3 R	IP14
3 S	IP54
4 and 4 X	IP66
5	IP52
6 and 6 P	IP67
12 and 12 K	IP52
13	IP54

Illustration 3

4. Measures against the formation of condensation

Different filling liquids depending on the ambient temperature and the electrical conductivity

In order to avoid the formation of condensation in the case, WIKA recommends filling the instruments with glycerine. For contact gauges, the filling can be made with silicone oil, since silicone oil, unlike glycerine, is not hygroscopic and therefore prevents a short circuit within the instrument.

If the ambient temperature drops below $-20\text{ }^{\circ}\text{C}$, then we recommend that the instrument absolutely must be filled with silicone oil. Even at temperatures down to $-50\text{ }^{\circ}\text{C}$, silicone oil can still be used due to its low viscosity.

For flammable and/or explosive media, e.g. oxygen, inert filling liquids must be used.

5. Hermetically sealed instruments and effects associated with them

In order to prevent the intrusion of water into the case, it is recommended that an ingress protection method is chosen that reliably inhibits this (see illustrations 1 and 2). The ingress protection demands that the instrument is hermetically sealed.

With vented instruments, the vent valve has to be closed in order to achieve the specified ingress protection. This, however, produces a temperature error, which can affect the measuring result (see illustrations 4, 5 and 6). Therefore the vent valve has to be opened for a short time before reading the measured value.

5.1 Temperature errors for unfilled and filled Bourdon tube pressure gauges

A standard 232.50/30 instrument with a pressure range greater than 25 bar can be made hermetically sealed without any problems, and manufactured with an ingress protection of IP66. The temperature error that occurs with these instruments is negligible, since it is so small in relation to the pressure range, that the instrument still will operate within its specified class accuracy.

Instruments with a scale range of less than 25 bar can likewise be made hermetically sealed, though a temperature error will then be present (see illustration 4). The temperature errors present are shown in the following graphs.

Temperature errors in hermetically sealed, unfilled Bourdon tube pressure gauges

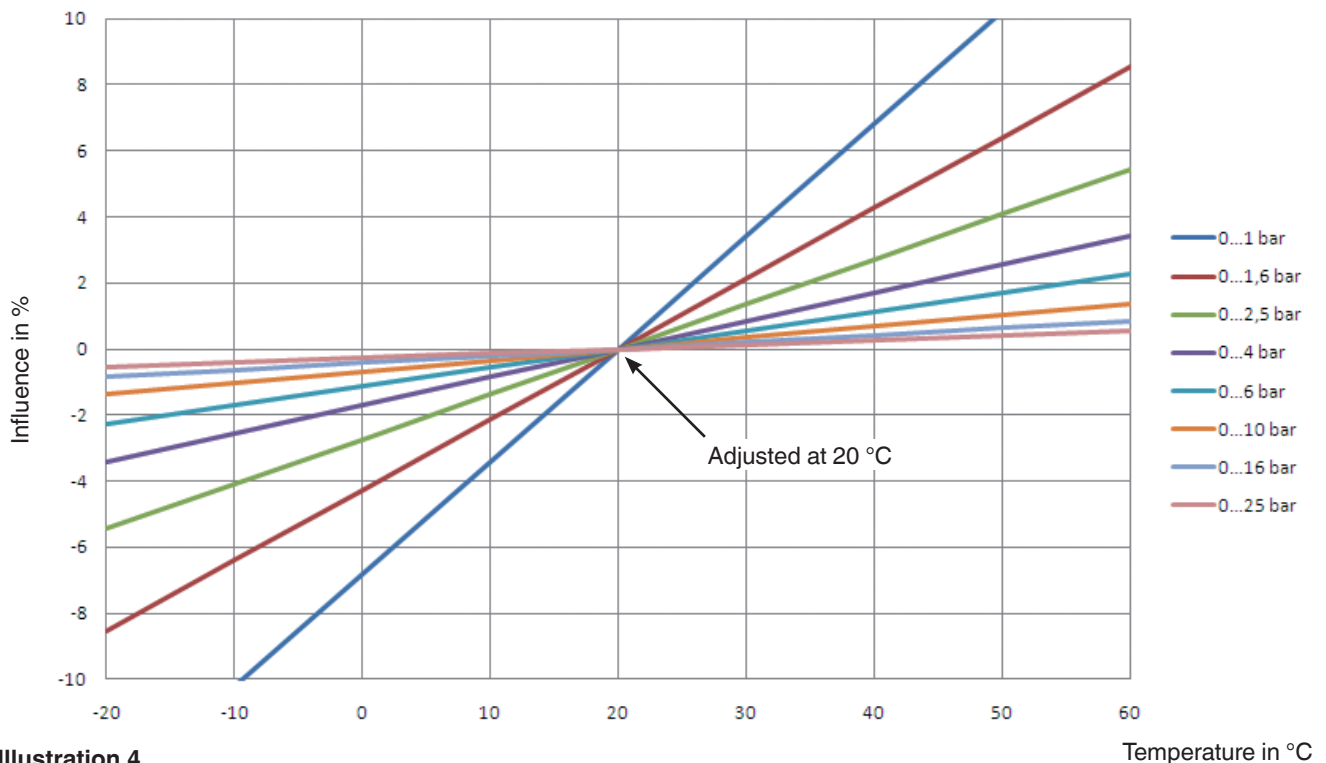
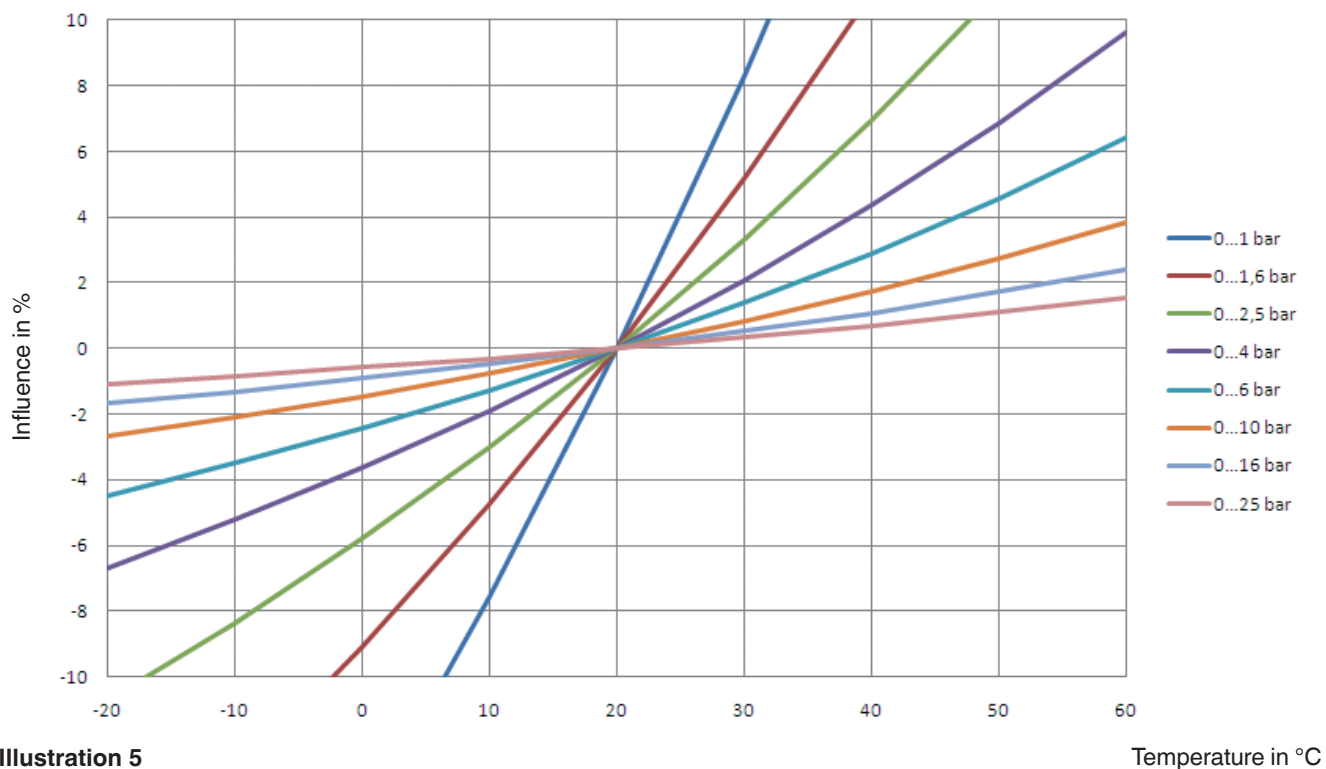

Illustration 4

Temperature errors in hermetically sealed, filled Bourdon tube pressure gauges

Filled to 90 % with glycerine



Filled to 90 % with silicone oil

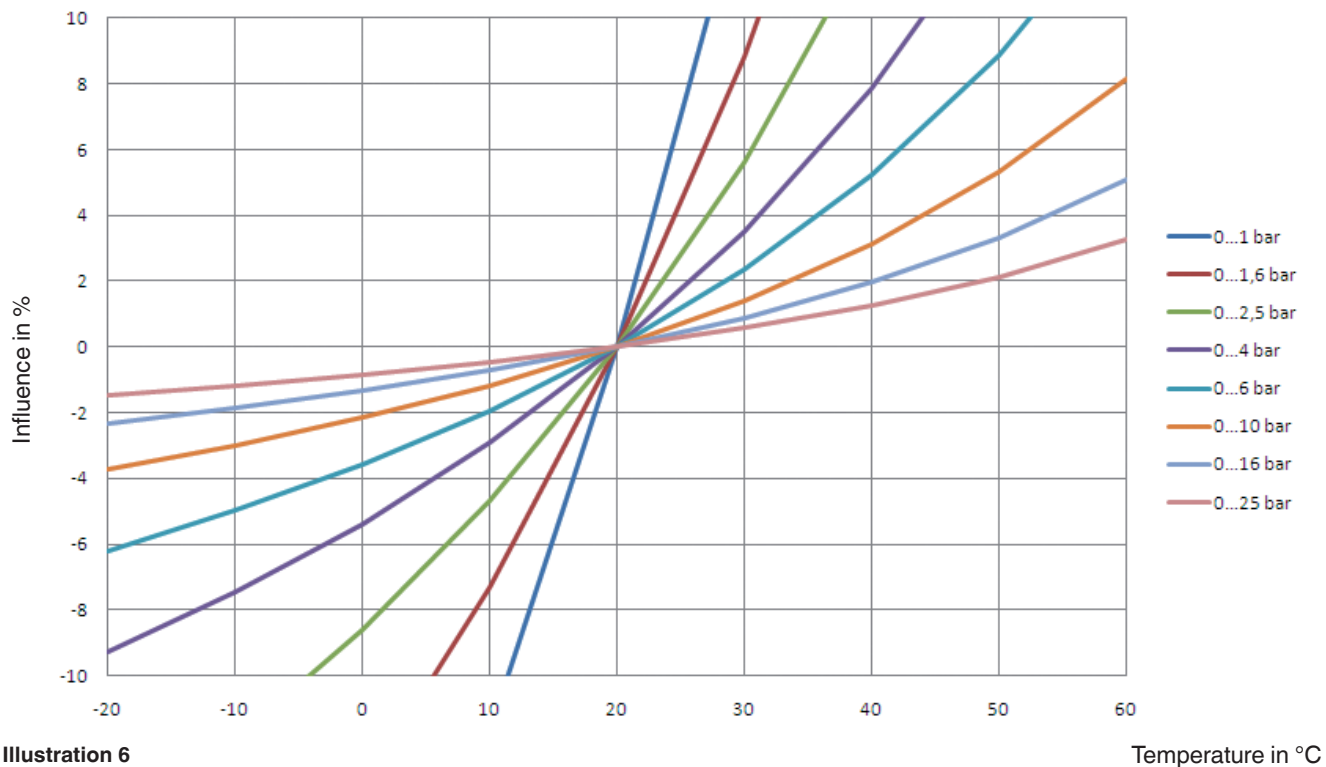

5.2 Temperature error with unfilled and filled diaphragm pressure gauges

With model 4, 5 and 7 hermetically sealed diaphragm pressure gauges, the temperature error for scale ranges ≥ 100 mbar is negligible. For scale ranges < 100 mbar we recommend only using instruments with a pressure compensation diaphragm.

For instrument models 73x.14, 702.01/02/03, 700.01/02 and 7x2.15, due to their mechanical design, there are no additional temperature errors.

5.3 Model overview

Pressure gauges for which the formation of condensation and the ingress of water from the outside can be prevented:

Influence	Bourdon tube pressure gauges					Diaphragm pressure gauges					
	Model 232.50 Model 232.30		Model 233.50 filled Model 233.30 filled		Model 233.30 filled, with pressure compen- sation diaphragm	Model 4 and 7		Model 4 and 7 filled		Model 4 and 7 with pres- sure com- pensation diaphragm	Model 4 and 7 filled, with pressure compensa- tion dia- phragm
	≥ 25 bar	< 25 bar	≥ 25 bar	< 25 bar	all pressure ranges	> 100 mbar	< 100 mbar	> 100 mbar	< 100 mbar	all pressure ranges	all pressure ranges
Formation of condensation	unavoidable		✓	✓	✓	unavoidable		✓	✓	unavoidable	✓
Hermetically sealed ¹⁾	Influence negligible	For influence see illustration 4	Influence negligible	For influence see illustration 5 or 6	✓	Influence negligible	Technically not solvable	Influence negligible	Technically not solvable	✓	✓

1) Hermetically sealed = airtight case

Illustration 7

6. Pressure compensation diaphragm

As can be seen in illustration 7, formation of condensation in filled pressure gauges can be prevented by the use of pressure compensation diaphragms, without any temperature error. Pressure compensation diaphragms can be used for all safety pressure gauges per EN 837-1 S3.

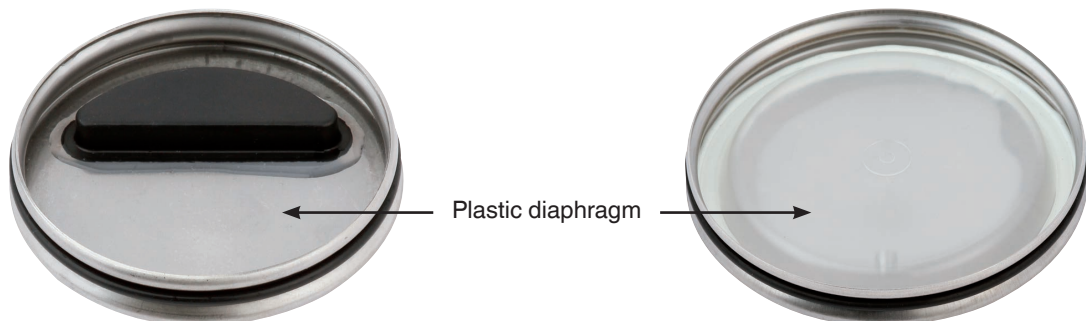

Illustration 8: Rear wall of case with pressure compensation diaphragm, nominal size 63

Illustration 9: Rear wall of case with pressure compensation diaphragm, nominal size 100

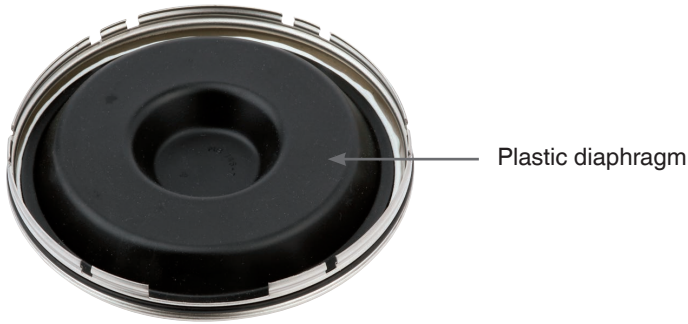

Illustration 10: Rear wall of case with pressure compensation diaphragm for contact gauges, nominal size 160

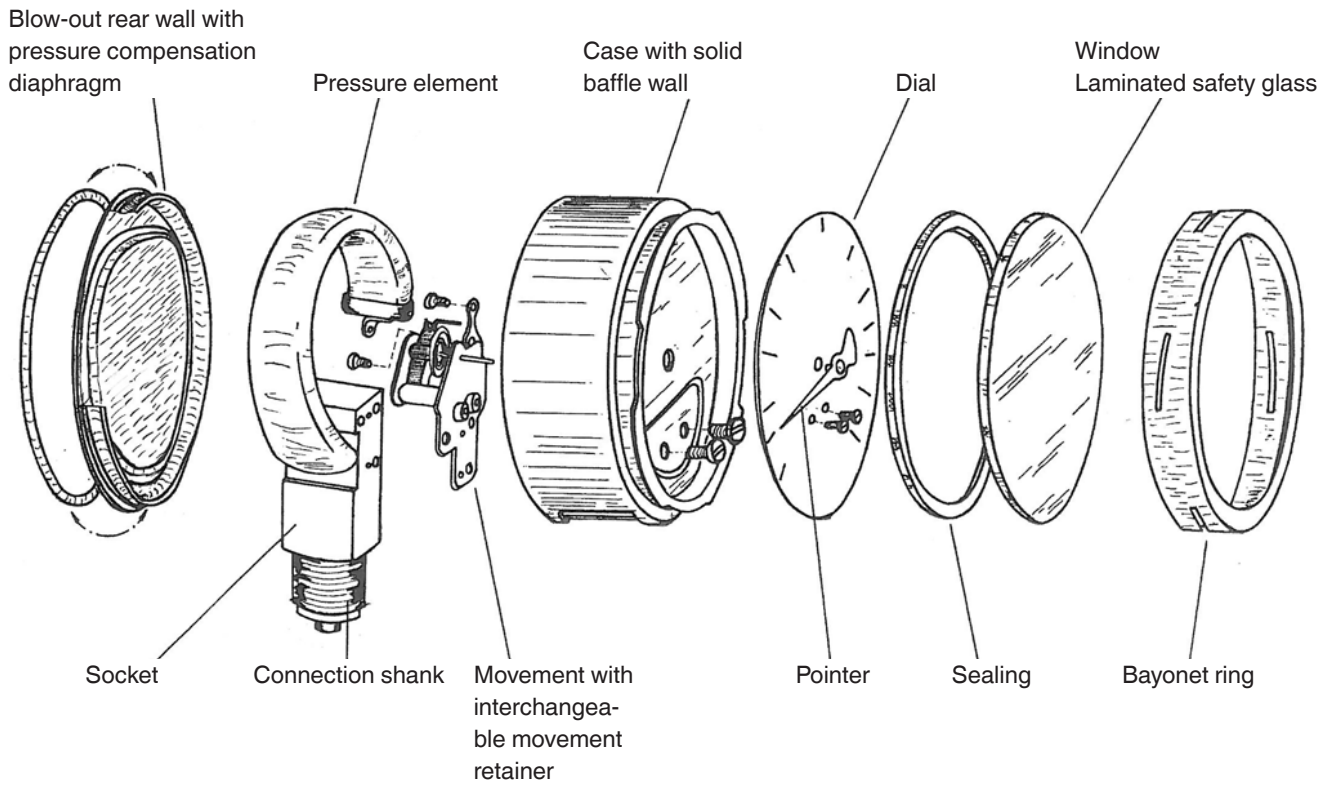

Illustration 11: Exploded view drawing

© 09/2010 WIKA Alexander Wiegand SE & Co. KG, all rights reserved.
 The specifications given in this document represent the state of engineering at the time of publishing.
 We reserve the right to make modifications to the specifications and materials.